

## MINI DIAPHRAGM VACUUM PUMPS AND COMPRESSORS

## DATA SHEET E 008

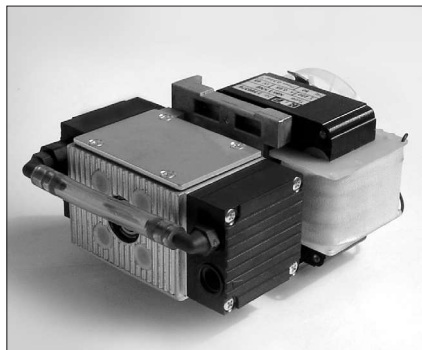

**N 85.3 KNE**



**N 86 KNDC**



**N 86 KNDCB**

### Concept

The Mini Diaphragm Vacuum Pumps from KNF are based on a simple principal - an elastic diaphragm, fixed on its edge, moves up and down its central point by means of an eccentric. In this way the medium is transferred using automatic valves.

The pumps are equipped with the patented stress-optimized structured diaphragm, resulting in a high pneumatic performance, a durable product and compact size. Special valves ensure that the product can cope easily with vapour and condensation.

Thanks to the KNF modular system, the parts used to transfer the gases can be made from materials with varying degrees of durability. The pumps can be driven by either AC or DC motors.

### Features

#### Uncontaminated flow

No contamination of the media due to oil-free operation

#### Maintenance-free

#### Compact size

due to structured diaphragm

#### High performance

because of structured diaphragm

#### High level of gas tightness

#### Long product life

thanks to structured diaphragm

#### Very quiet and little vibration

#### Copes well with vapour and condensation

#### Cool running motor

even when in constant use

#### Ready for assembly

Can operate in any installed position

### Areas of use

The Mini Diaphragm Vacuum Pumps offer a high level of performance despite their small size, as well as an excellent price performance ratio. They are required especially in the fields of analysis, medicine and production technology.

The pumps are used for sucking gases, taking samples (even liquids in a vacuum) and evacuating vessels.

The AC models are suited for use in machinery which is permanent or mains-operated. Mini Diaphragm Pumps for portable and stand-alone equipment require DC power supplies.

## PERFORMANCE DATA

Type	Delivery (l/min)	Vacuum (mbar abs)	atm. Press.	Pressure (bar g)	Weight (kg)
N 85.3 KNE	5	25		0.3	1.25
N 85.3 KNDC	5	25		0.3	0.72
N 86 KNE	6	100		2.4	1.1
N 86 KNDCB	6	100		2.4	0.56
N 86 KNDC	6.5	100		1.5	0.58

# N 85.3 KNE N 85.3 KTE

# N 85.3 KNDC N 85.3 KTDC

## PERFORMANCE DATA

Type and Order No. <sup>2)</sup>	Delivery at atm. pressure (l/min) <sup>1)</sup>	Max. operating pressure (bar g)	Ultimate vacuum (mbar abs.)
N 85.3 KNE	5	0.3	25
N 85.3 KTE	5	0.3	35

<sup>1)</sup> Litre at STP

## MOTOR DATA

Protection class	IP 00		
Voltage/Frequencies (V/Hz)	230/50		
Power P <sub>1</sub> (W)	65		
Operating current (A)	0.65		

## MODEL CODES AND MATERIALS

Type and Order No. <sup>2)</sup>	Pump head	Diaphragm	Valves
N 85.3 KNE	Ryton <sup>4)</sup>	EPDM	CR
Chemically resistant version			
N 85.3 KTE	Ryton <sup>4)</sup>	PTFE-coated	FFPM

<sup>2)</sup> See also „MODEL CODES FOR EASY ORDERING“

<sup>4)</sup> Phillips Petroleum, registered trade mark

## Dimensions <sup>5)</sup> (mm)

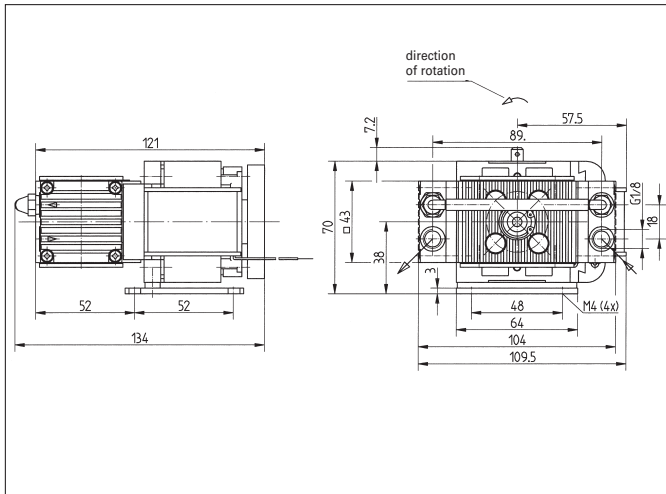

<sup>5)</sup> All dimensional tolerances conform to DIN ISO 2768-1, Tolerance Class V

## PERFORMANCE DATA

Type and Order No. <sup>2)</sup>	Delivery at atm. pressure (l/min) <sup>1)</sup>	Max. operating pressure (bar g)	Ultimate vacuum (mbar abs.)
N 85.3 KNDC	5	0.3	25
N 85.3 KTDC	5.5	0.3	35

<sup>1)</sup> Litre at STP

## MOTOR DATA

DC Motor	12V	24V	
Operating current (A)	1.4	0.7	

## MODEL CODES AND MATERIALS

Type and Order No. <sup>2)</sup>	Pump head	Diaphragm	Valves
N 85.3 KNDC	Ryton <sup>4)</sup>	EPDM	CR
Chemically resistant version			
N 85.3 KTDC	Ryton <sup>4)</sup>	PTFE-coated	FFPM

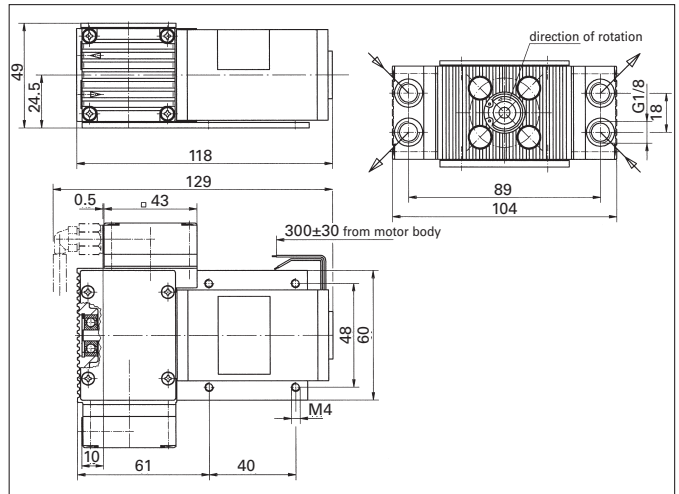

### N 85.3 KNE

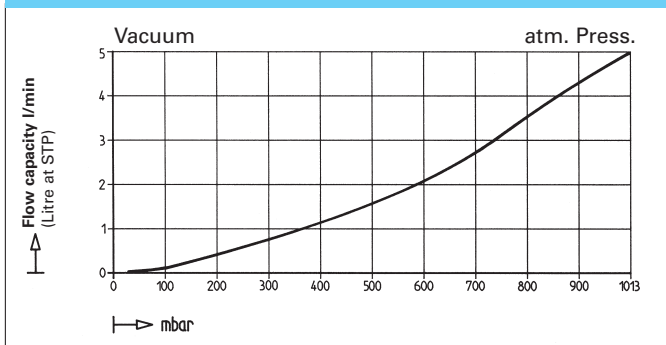

### N 85.3 KNDC

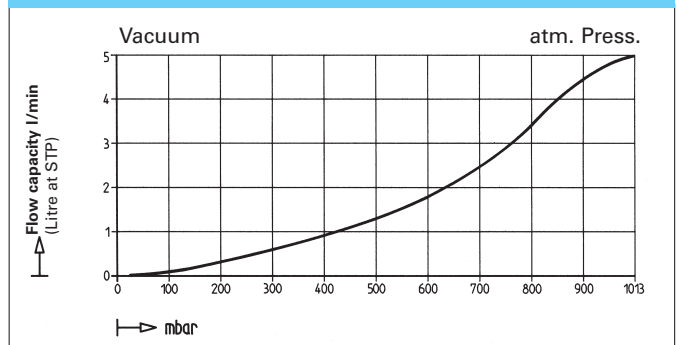

### N 85.3 KTE

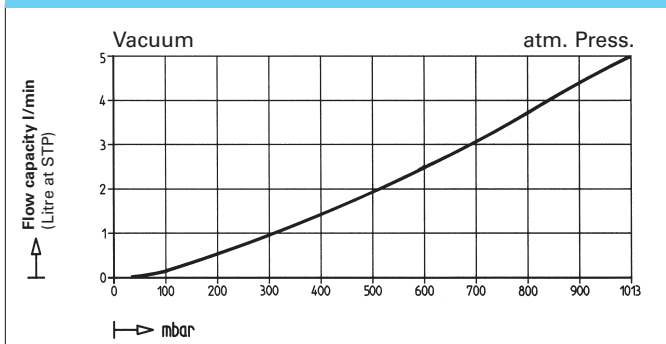

### N 85.3 KTDC

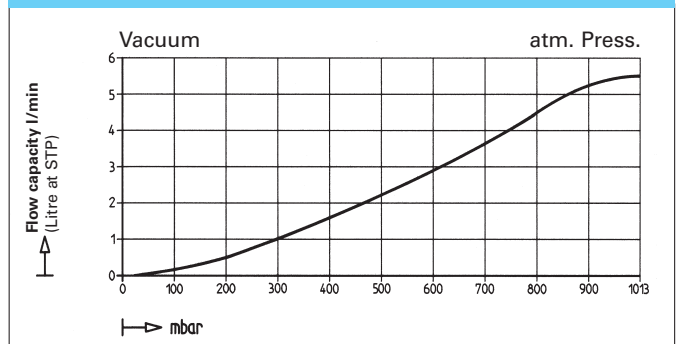

# N 86 KNE N 86 KTE

## PERFORMANCE DATA

Type and Order No. <sup>2)</sup>	Delivery at atm. pressure (l/min) <sup>1)</sup>	Max. operating pressure (bar g)	Ultimate vacuum (mbar abs.)
<b>N 86 KNE</b>	6	2.4	100
<b>N 86 KTE</b>	5.5	2.5	160

<sup>1)</sup> Litre at STP

## MOTOR DATA

Protection class	IP 00		
Voltage/Frequencies (V/Hz)	230/50		
Power P <sub>1</sub> (W)	60		
Operating current (A)	0.65		

## MODEL CODES AND MATERIALS

Type and Order No. <sup>2)</sup>	Pump head	Diaphragm	Valves
<b>N 86 KNE</b>	Ryton <sup>4)</sup>	EPDM	FPM
Chemically resistant version			
<b>N 86 KTE</b>	Ryton <sup>4)</sup>	PTFE-coated	FFPM

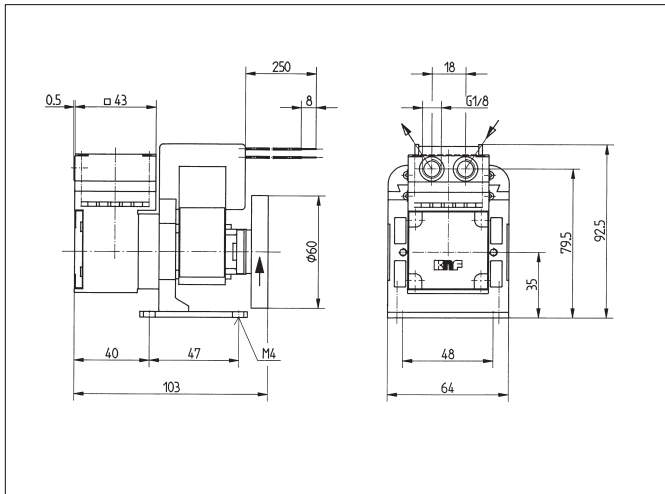

## N 86 KNE

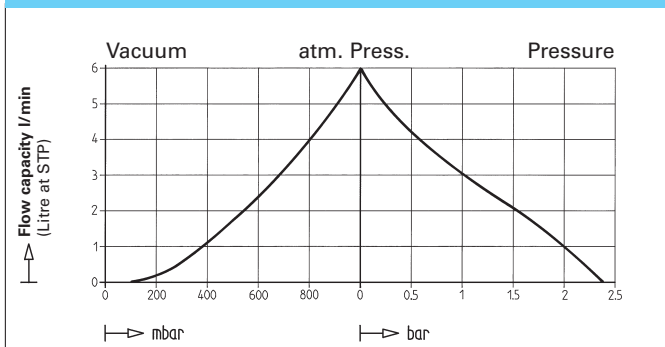

## N 86 KTE

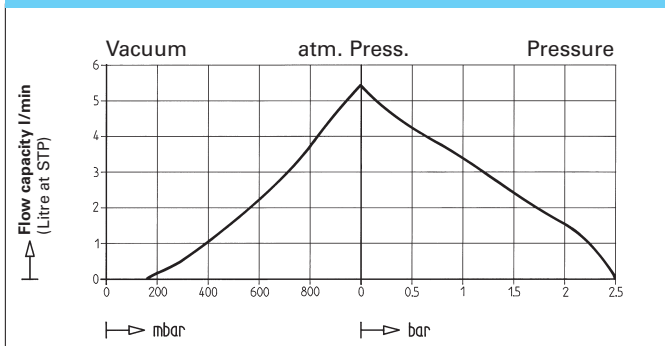

# N 86 KNDCB N 86 KTDCB

## VERSION WITH BRUSHLESS DC MOTOR

## PERFORMANCE DATA

Type and Order No. <sup>2)</sup>	Delivery at atm. pressure (l/min) <sup>1)</sup>	Max. operating pressure (bar g)	Ultimate vacuum (mbar abs.)
<b>N 86 KNDCB</b>	6	2.4	100
<b>N 86 KTDCB</b>	5.5	2.5	160

<sup>1)</sup> Litre at STP

## MOTOR DATA

DC Motor	12 V	24 V	
Operating current a) (A)	1.1	0.65	
Operating current b) (A)	1.0	0.6	

a) for Type **N 86 KNDCB** b) for Type **N 86 KTDCB**

## MODEL CODES AND MATERIALS

Type and Order No. <sup>2)</sup>	Pump head	Diaphragm	Valves
<b>N 86 KNDCB</b>	Ryton <sup>4)</sup>	EPDM	FPM
Chemically resistant version			
<b>N 86 KTDCB</b>	Ryton <sup>4)</sup>	PTFE-coated	FFPM

To comply with CE standards (EMC guidelines to EN 55014-1), attention must be paid to the specifications in the operating instructions.

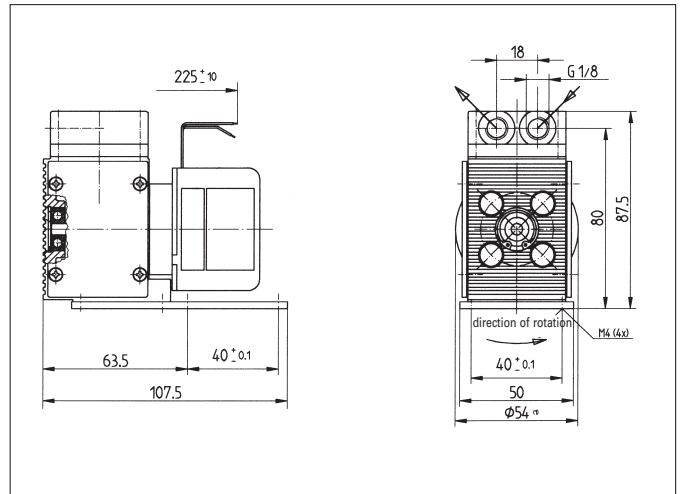

## N 86 KNDCB

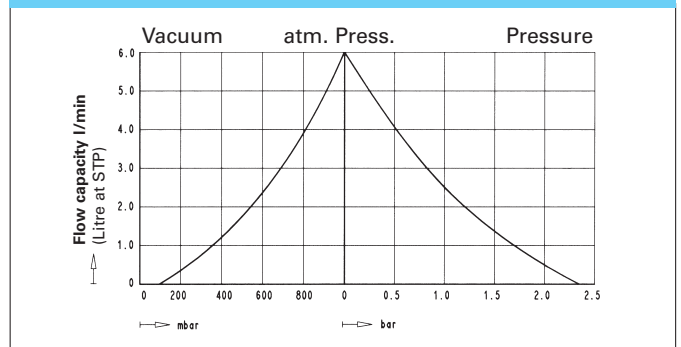

## N 86 KTDCB

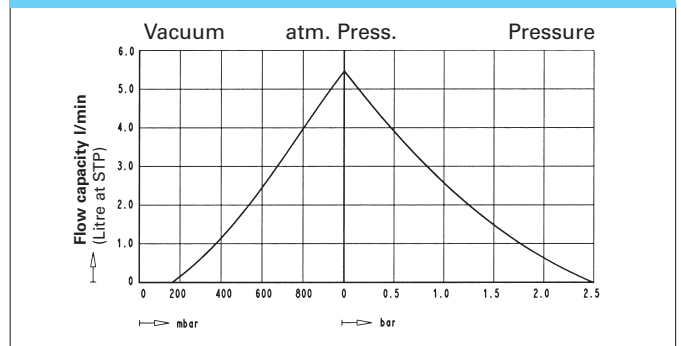

# N 86 KNDC N 86 KTDC

## PERFORMANCE DATA

Type and Order No. <sup>2)</sup>	Delivery at atm. pressure (l/min) <sup>1)</sup>	Max. operating pressure (bar g) <sup>3)</sup>	Ultimate vacuum (mbar abs.)
<b>N 86 KNDC</b>	6.5	1.5	100
<b>N 86 KTDC</b>	6	1.5	160

<sup>1)</sup> Litre at STP

<sup>3)</sup> continuous running

## MOTOR DATA

DC Motor	12 V	24 V	
Operating current a) (A)	1.3 A	0.65 A	
Operating current b) (A)	1.5 A	0.75 A	

a) for Type **N 86 KNDC** b) for Type **N 86 KTDC**

## MODEL CODES AND MATERIALS

Type and Order No. <sup>2)</sup>	Pump head	Diaphragm	Valves
<b>N 86 KNDC</b>	Ryton <sup>4)</sup>	EPDM	FPM
Chemically resistant version			
<b>N 86 KTDC</b>	Ryton <sup>4)</sup>	PTFE-coated	FFPM

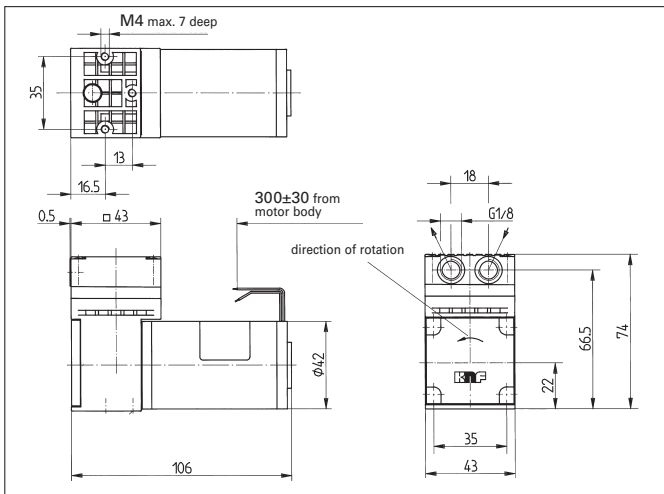

## N 86 KNDC

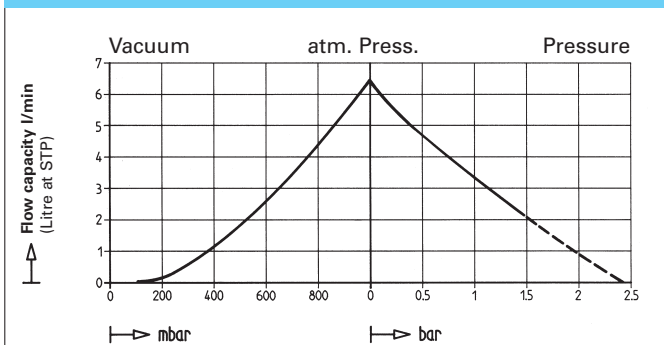

## N 86 KTDC

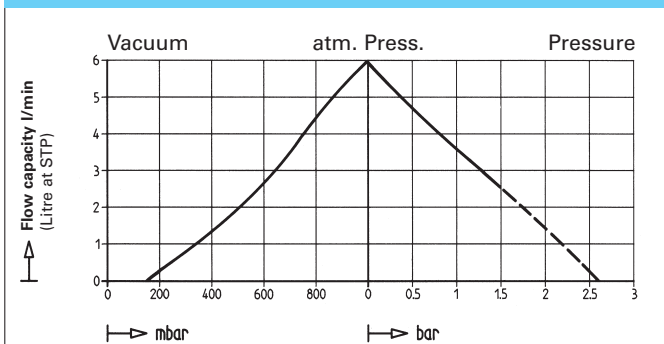

----- for short periods only

## Pump down time for 5 l receiver

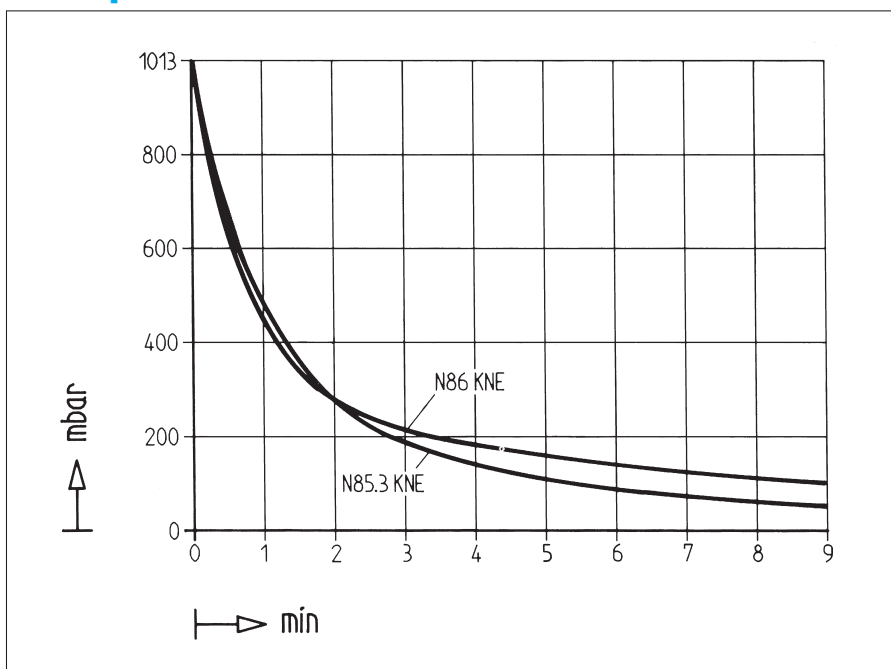

## MODEL CODE FOR EASY ORDERING

The model code is identical to the order number. It is made up as follows:

<b>N 85</b>	<b>.3</b>	<b>KN</b>	<b>E</b> <b>DC</b>	<b>230 V/50 Hz,</b> <b>IP 00 or 12 V</b>
-------------	-----------	-----------	-----------------------	---

- Base model
- Head connections
- Head materials
- OEM Versions with ac (E) or dc motor (DC)
- Other motor data eg.: \_\_\_\_\_

In addition the motor data must be given in the purchase order (voltage, frequency, and protection class). In our extensive program you are sure to find the pump you need for your particular application.

## TECHNICAL DETAILS

Maximum permissible gas and ambient temperature 40°C.

Motors with other voltages, frequencies and protection classes on request.

## Head connections

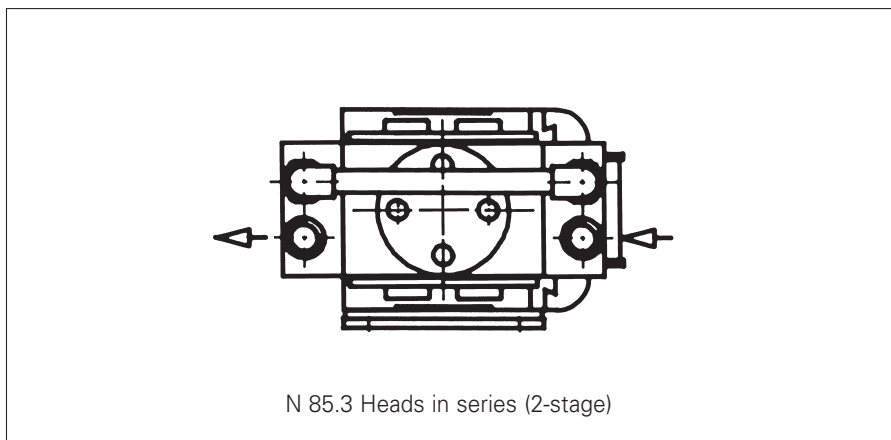

Hints on function, installation and service: see back side

KNF - the competent partner for vacuum and compressor technology. Especially for unusual problems. Call us and talk to our application engineers.

## Accessories

Description	Order No.	Details
Silencer	000345	
Filter	000346	
Hose connector	001936	PA
Hose connector	025671	PVDF
Rubber foot	024435	for N 85.3/N 86_ E

## HINTS ON FUNCTION, INSTALLATION AND SERVICE

### FUNCTION OF KNF DIAPHRAGM VACUUM PUMPS AND COMPRESSORS

An elastic diaphragm is moved up and down by an eccentric (see illustration). On the down-stroke it draws the air or gas being handled through the inlet valve. On the up-stroke the diaphragm forces the medium through the exhaust valve and out of the head. The compression chamber is hermetically separated from the drive mechanism by the diaphragm. The pumps transfer, evacuate and compress completely oil-free.

#### Diaphragm pump

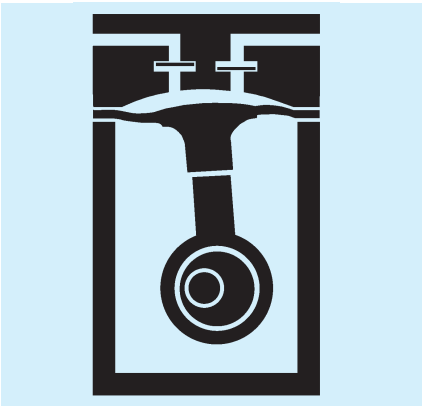

### HINTS ON INSTALLATION AND OPERATION

- Range of use: Transferring air and gases at temperatures between +5°C and +40°C
- Please check the compatibility of the materials of the pump head, diaphragm and valves with the medium.
- The KNF product line contains pumps suitable for pumping aggressive gases and vapours - please contact us.
- Permissible ambient temperature: between +5°C and +40°C
- The standard pumps are not suitable for use in areas where there is a risk of explosion. In these cases there are other products in the KNF program - please ask us for details
- The pumps are not designed to start against pressure or vacuum; when a pump is switched on the pressure in the suction and pressure lines must be atmospheric. Pumps that start against pressure or vacuum are available on request
- To prevent the maximum operating pressure being exceeded, restriction or regulation of the air flow should only be carried out in the suction line

- Components connected to the pump must be designed to withstand the pneumatic performance of the pump
- Install the pump so that the fan can draw in sufficient cooling air
- Fit the pump at the highest point in the system, so that condensate cannot collect in the head of the pump - that prolongs working-life.

### HINTS ON SERVICE

The diaphragm and valve plates are the only parts of the KNF diaphragm pumps subject to wear. They are easy to change, as no special tools are needed.

If you have any questions, please call our application engineers (see below for contact telephone number).

### KNF Neuberger GmbH Diaphragm Pumps + Systems

Alter Weg 3  
D 79112 Freiburg  
Tel. ++49 (0)7664/5909-0  
Fax ++49 (0)7664/5909-99  
www.knf.de  
E-mail: info@knf.de

## SALES CENTERS

### **Germany**

KNF Neuberger GmbH  
D-79112 Freiburg  
Tel. +49 7664 5909 0  
info@knf.de  
www.knf.de

### **Benelux Netherlands**

KNF Verder B.V.  
NL-3451 GG Vleuten  
Tel. +31 30 677 92 40  
info@knf-verder.nl  
www.knf-verder.nl

### **Benelux Belgium and Luxemburg**

KNF Verder N.V.  
B-2630 Aartselaar  
Tel. +32 3 871 96 24  
info@knf.be  
www.knf.be

### **China**

KNF Technology (Shanghai) Co., Ltd.  
Shanghai 201203  
Tel. +86 21 5109 9695  
info@knf.com.cn  
www.knf.com.cn

### **France, Morocco, Tunisia, Algeria**

KNF Neuberger SAS  
F-68128 Village-Neuf  
Tel. +33 389 70 35 00  
info@knf.fr  
www.knf.fr

### **UK**

KNF Neuberger U.K., Ltd.  
Witney, Oxfordshire OX28 4FA  
Tel. +44 1993 77 83 73  
info@knf.co.uk  
www.knf.co.uk

### **India**

KNF Pumps + Systems (India) Pvt. Ltd.  
Hinjewadi, Pune 411 057  
Tel. +91 20 640 13 923  
+91 20 640 08 923  
info@knfpumps.in  
www.knfpumps.in

### **Italy**

KNF ITALIA S.r.l.  
I-20063 Cernusco s. Naviglio MI  
Tel. +39 02 272 03 860  
info@knf.it  
www.knf.it

### **Japan**

KNF Japan Co.Ltd.  
Tokyo 104-0033  
Tel. +81 3 3551 7931  
info@knf.co.jp  
www.knf.co.jp

### **Korea**

KNF Neuberger Ltd.  
135-502, Seoul  
Tel. +82 2 959 0255  
knf@knfkorea.com  
www.knfkorea.com

### **Sweden, Finland, Denmark, Norway**

KNF Neuberger AB  
SE-11743 Stockholm  
Tel. +46 8 744 51 13  
info@knf.se  
www.knf.se

### **Switzerland**

KNF Neuberger AG  
CH-8362 Balterswil  
Tel. +41 71 973 99 30  
knf@knf.ch  
www.knf.ch

### **Taiwan**

KNF Neuberger Ltd.  
Taipei City, 11490  
Tel. +886 2 2794 1011  
knftwn@knftwn.com.tw  
www.knftwn.com.tw

### **USA, Canada**

KNF Neuberger, Inc.  
Trenton, New Jersey 08691-1810  
Tel. +1 609 890 8600  
knfusa@knf.com  
www.knfusa.com

### **Latin America**

Tel. +1 609 649 1010  
gb@knf.com  
www.knf.com/es